



## KENTUCKY TRANSPORTATION CENTER

### **RAILROAD SUBGRADE SUPPORT AND PERFORMANCE INDICATORS**

**A Review of Available Laboratory and In-Situ Testing Methods**





## **OUR MISSION**

**We provide services to the transportation community**  
through research, technology transfer and education.

We create and participate in partnerships  
to promote safe and effective  
transportation systems.

## **OUR VALUES**

### **Teamwork**

Listening and communicating along with  
courtesy and respect for others.

### **Honesty and Ethical Behavior**

Delivering the highest quality  
products and services.

### **Continuous Improvement**

In all that we do.

Research Report  
KTC-12-02 / FR 136-04-6F

**RAILROAD SUBGRADE SUPPORT AND PERFORMANCE INDICATORS**

**A Review of Available Laboratory and In-Situ Testing Methods**

by

Michael T. Henry  
Graduate Research Assistant

and

Jerry G. Rose  
Professor

Department of Civil Engineering

and

Kentucky Transportation Center  
College of Engineering  
University of Kentucky  
Lexington, Kentucky

The contents of this report reflect the views of the authors who are responsible for the facts and accuracy of the data presented herein. The contents do not necessarily reflect the official views of policies of the University of Kentucky, the Kentucky Transportation Cabinet, or the Federal Highway Administration. This report does not constitute a standard, specification, or regulation. The inclusion of manufacture names and trade names is for identification purposes and is not to be considered an endorsement.

February 2012

<b>1. Report No.</b> KTC-12-02/FR 136-04-6F	<b>2. Government Accession No.</b>	<b>3. Recipient's Catalog No.</b>	
<b>4. Title and Subtitle</b>  Railroad Subgrade Support and Performance Indicators — A Review of Available Laboratory and In-Situ Testing Methods		<b>5. Report Date</b>  February 2012	
		<b>6. Performing Organization Code</b>	
		<b>8. Performing Organization Report No.</b> KTC-12-02	
<b>7. Authors</b>  Michael T. McHenry and Jerry G. Rose		<b>10. Work Unit No. (TRIAS)</b>	
<b>9. Performing Organization Name and Address</b>  Kentucky Transportation Center College of Engineering University of Kentucky Lexington, KY 40506-0281		<b>11. Contract or Grant No.</b>  FRT 136	
<b>12. Sponsoring Agency Name and Address</b>  Kentucky Transportation Cabinet 200 Mero Street Frankfort, KY 40622		<b>13. Type of Report and Period Covered</b>  Final Report – KTC-12-02 7/1/2004 – 6/30/2009	
		<b>14. Sponsoring Agency Code</b>	
<b>15. Supplementary Notes</b> Prepared in cooperation with the Kentucky Transportation Cabinet and United States Department of Transportation, Federal Highway Administration			
<b>16. Abstract</b> The quality and support of the subgrade portion of a railroad trackbed are vital to the overall performance of the track structure. The subgrade is an integral component of the track structure and its performance properties must be considered in order to effectively assess its influence on subsequent track quality. European and Asian railways are particularly advanced in implementing subgrade performance indicators into their track designs and assessments. As train speed and tonnage increase in the U.S., the evaluation and influence of subgrade performance will become even more paramount. There are numerous means of measuring and predicting subgrade performance. Both laboratory and in-situ test methods have been used. A review of available testing methods is presented herein in the context of railroad subgrade assessment. Discussion on the applicability of each test to the American railroad industry is also included. In-situ tests likely provide the greater advantage in railway engineering because results can typically be obtained quickly, more cost effectively, and with a larger data set. Newer rail-bound, continuous testing devices, while not testing the subgrade directly, are extremely convenient and will likely become more common in the future.			
<b>17. Key Words</b> Railroad, subgrade support, subgrade performance, laboratory/in-situ subgrade tests		<b>18. Distribution Statement</b> Unlimited, with approval of the Kentucky Transportation Cabinet	
<b>19. Security Classification (of this report)</b> Unclassified	<b>20. Security Classification (of this page)</b> Unclassified	<b>21. No. of Pages</b> 36	<b>22. Price</b>

## **Table of Contents**

<b>1.0 Introduction.....</b>	<b>1</b>
<b>2.0 Trackbed Design .....</b>	<b>2</b>
<b>3.0 Measuring Subgrade Performance .....</b>	<b>4</b>
<b>3.1 Laboratory Tests.....</b>	<b>4</b>
<b>3.2 In-Situ Tests.....</b>	<b>13</b>
<b>4.0 Other In-Situ Tests for Railroad Trackbeds.....</b>	<b>27</b>
<b>5.0 Discussion and Conclusions .....</b>	<b>29</b>
<b>References .....</b>	<b>30</b>

## List of Tables and Figures

### Figures

1. Idealized trackbed cross-section
2. Typical American track substructure: clean ballast on a ballast soil conglomerate, eventually reaching a subgrade soil.
3. Unconfined Compression Test
4. Direct Shear Test
5. Stress relationship for a direct shear test on a granular soils
6. California Bearing Ratio Test
7. Triaxial Test parameters
8. Example of what a split cell triaxial sample might look like to test the effectiveness of a geosynthetic in pumping prevention
9. Typical stress-strain behavior of a cyclically loaded soil showing the accumulated plastic strain and resilient modulus
10. Cyclic loading tests: a) Simple Shear sample, b) Hollow Cylinder Apparatus sample, and c) Resonant Column Apparatus
11. Field Vane Shear Test
12. a) Plate Load Test diagram showing various plate sizes available and b) PLT being performed from below a truck.
13. Standard Penetration Test with split-spoon sampler
14. Typical CPTU cone showing possible locations for pore pressure measurement
15. Stratigraphics CPT truck outfitted with High Railers performing penetration testing on an existing trackbed in Wisconsin
16. PANDA Penetrometer
17. Full-Displacement Pressuremeter
18. The Flat Dilatometer
19. Typical FWD mounted on a trailer for use on highway pavement surfaces
20. A LWFD being used on an asphalt trackbed layer in Austria
21. The Portancemètre
22. DyStaFiT testing device
23. A version of the adapted Portancemètre during its development
24. Track Loading Vehicle (TLV) and TTCI Test Track in Pueblo, Colorado

### Tables

1. Applicability of Standard In-Situ Tests for Various Parameters and Soil Conditions

## 1.0 Introduction

Despite its importance in track design, only a limited amount of information is available regarding the evaluation of subgrade performance in railroad trackbeds. Historically, the substructure has been given less attention than the superstructure of a railroad trackbed (Selig and Waters, 1994). The subgrade provides the roadbed upon which all other components of the track structure are placed and has a significant impact on the track's ultimate quality and required maintenance. Figure 1 presents the typical idealized railway substructure.

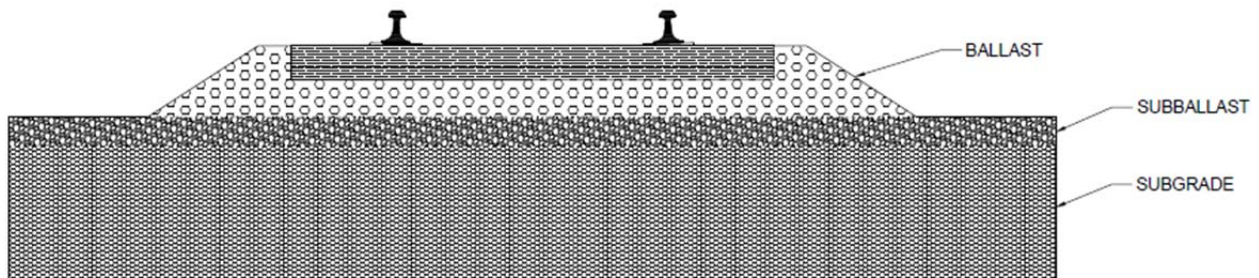

*Figure 1: Idealized trackbed cross-section*

At least a portion of the difficulty in the evaluation of subgrade is that so many factors affect its performance including classification properties, moisture content, shear strength, consolidation, and stiffness parameters. Ballast fouling, ballast pockets, pumping of soil fines through the ballast, and slope stability failure are all issues that can arise as a result of poor subgrade and drainage conditions. Additionally, the loading characteristics of the track dictate the required quality of subgrade. These include the type of transport (freight or passenger), train speed, axle loads, train configuration, wheel condition, tie spacing, and rail condition (Neidhart and Shultz, 2011).

Section 2 discusses subgrade and trackbed design procedures. Section 3 presents typical laboratory and in-situ testing procedures that have potential for American railway applications. While this may serve as a basic overview of soil testing, the goal is to focus on the railway engineering applications of each testing procedure, for which limited railway research exists. Section 4 covers some of the new rail-bound, continuous testing devices and Section 5 presents general discussion and conclusions.

## 2.0 Trackbed Design

In the U.S., A.N. Talbot and his committee performed and developed much of the early trackbed design practices. His classic design procedure varied the thickness of the ballast section based on an assumed bearing capacity of the subgrade (Hay, 1982). Modern track design and the American Railway Engineering and Maintenance-of-Way Association (AREMA) Manual for Railway Engineering Recommended Practices suggests limiting the stress on the subgrade to 20 psi (AREMA, 2010). Talbot's design does not include consideration for subballast or capping layer, nor the effects of repeated loadings. Two equations have traditionally been used to select ballast thickness (Selig and Waters, 1994):

$$P_c = \frac{50P_m}{10+h^{1.35}} \quad (\text{Japanese National Railways Equation}) \quad (1)$$

$$P_c = \frac{16.8 P_a}{h^{1.25}} \quad (\text{Talbot Equation}) \quad (2)$$

Where:

$P_c$  = subgrade pressure (kPa for JNR Equation and psi for Talbot Equation)

$P_m$  or  $P_a$  = applied stress on the ballast (same units as  $P_c$ )

$h$  = ballast depth (cm for JNR Equation and in. for Talbot Equation)

Allowed subgrade pressures are determined, most typically, using the Unconfined Compression Test or the California Bearing Ratio Test, although most often they are assumed. While this approach does take into account the strength of the subgrade, it fails to consider the soil's deformability and subsequent settlement over time (Gallego et al., 2011). European nations including France, Italy, and Germany as well as Japan have typically performed bearing capacity testing on track subgrades and subballasts, using this data to design for layer thicknesses. It has not been until recently that layer stiffness or modulus has been incorporated into international design to account for trackbed deformation. (Rose, Teixeira, & Ridgeway, 2010). Obviously, international railways recognize the importance of track stiffness and its effect on design practices.

This approach treats the subgrade as an external component that is not integral to the trackbed itself. Many of these design standards are based on early work by A.N. Talbot and fail to take into account several important factors, including quality of materials (both aggregates and soils), effect of repeated loading cycles, and the magnitude of these loads. As trackbed design evolves it will be necessary to treat the subgrade as an integral part of the trackbed that operates in harmony with the sub-ballast, ballast, ties, and rail.

Most trackbeds in the U.S., in contrast with those of the European and Asian high-speed network, have not been "engineered." Older trackbeds that have not been completely rebuilt consist of a ballast bed resting on subgrade soil as shown in Figure 2. Between the two layers is usually a layer of ballast-soil conglomerate composed of



deteriorated ballast and soil fines. This layer acts as a quasi-subballast, but is extremely varied in composition and difficult to assess. Traditionally, as the trackbed settles to an undesirable level due to subgrade settlement and ballast degradation, ballast is added to raise the track. This typically does not solve the problem and after some time in service, more ballast is required. This cyclic process of ballast dumping, surfacing, and subsequent track settlement has been the status quo in the U.S. since the 19<sup>th</sup> century. With high maintenance costs and short maintenance windows, it is becoming more desirable to better understand the performance of subgrade soils under railway loading in the U.S.

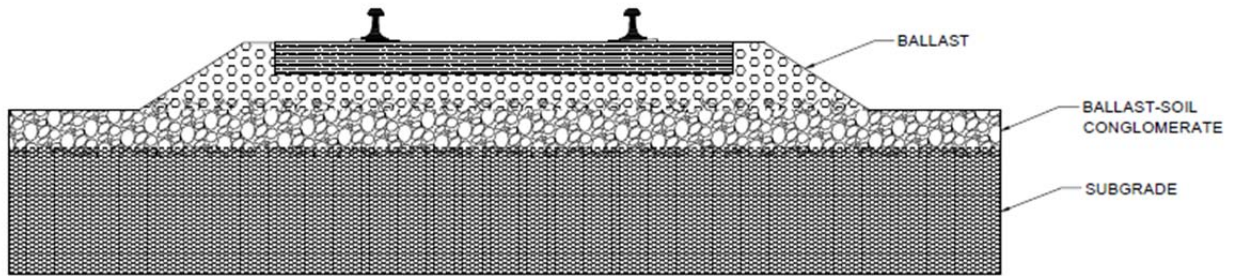

*Figure 2: Typical American track substructure: clean ballast resting on a ballast-soil conglomerate, eventually reaching a subgrade soil.*

### **3.0 Measuring Subgrade Performance**

Railroad subgrade, and soil performance in general, is governed by two characteristics – strength and deformation (Selig and Lutenecker, 1991). Strength refers to the soil’s shear strength properties and whether or not the allowable shear strength in the soil has been exceeded by the applied shear stress. This characteristic is often quantified with the bearing capacity or undrained shear strength parameters. Deformation refers to settlement (both elastic and plastic) occurring in the subgrade. The elastic settlement of a trackbed can easily be observed as a heavy freight train passes by. The track deforms downward and rebounds as the loading is released. The plastic, and thus permanent, settlement of the trackbed is harder to observe, however. The distinction between strength and stiffness (deformation per a given load) is important to understand in railroad subgrade design. Bearing capacity is considered to be the general indicator of strength, while elastic deformation per applied load intensity is represented by the soil modulus. It should also be noted that the stratification of the subgrade may also affect track performance.

Of particular interest to trackbed research are the availability of in-situ and laboratory tests to determine a subgrade’s modulus. Trackbed design programs, such as KENTRACK and GEOTRACK (Selig and Waters, 1994), require the input of a subgrade modulus for structural analysis. The output of KENTRACK is a life cycle estimate of the trackbed structure. The life cycle output can only be as reliable as the input parameters. In fact, it is often found in such analyses, that the subgrade quality dictates the overall life cycle of the trackbed (Rose and Konduri, 2006).

Strength and deformation properties are both important in measuring subgrade performance. Overall track stiffness, of which subgrade stiffness is a segment of, typically is not considered in U.S. trackbed design practices. Therefore, it is advantageous for future subgrade testing to have a means of calculating soil modulus as track stiffness becomes a prevailing means of designing and assessing railroad trackbeds.

### **3.1 Laboratory Tests**

Prior to determining a soil’s strength and deformation properties, it is necessary to run the gamut of soil characterization tests to determine the type of soil that is being tested and evaluated. Numerous laboratory tests are used to do so including the Atterberg Limits --- Liquid Limit Test (ASTM D423) and Plastic Limit Test (ASTM D424), Moisture Content Test (ASTM D2216), and Moisture Density Test --- Proctor (ASTM D698 ) as well as Grain Size Distribution testing. These characteristics are used to classify the soil, typically according to the Unified Soil Classification System. The AREMA Manual for Railway Engineering (2010) presents the range of soil classifications and their predicted suitability for railway subgrade applications.

Historically, moisture content has been known to have major implications in the performance of most all soils and especially railroad subgrades. In-situ moisture contents at a particular site vary significantly. The shear strength of a soil, for example, dissipates rapidly for many soil types as the soil’s moisture content increases beyond optimum. Laboratory soil tests to determine both strength and deformation properties follow.

### 3.1.1 Unconfined Compression Strength Test (ASTM D2166)

The unconfined compression test is simply an unconsolidated, undrained (UU) triaxial test run without a confining pressure. The specimen is sheared quickly enough, so that the drainage of pore water is minimal. The test is limited to soils with sufficient cohesion to permit testing without confinement (typically clays). It is recommended that the unconfined compression test only be used with clays that are normally consolidated to slightly overconsolidated, since heavily overconsolidated soil specimens may contain fissures that act as planes of weakness. In the case of heavily overconsolidated specimens, a UU triaxial test should be used. Figure 3 shows the standard setup for an unconfined compression test.

The unconfined compression test is performed by straining a cylindrical soil specimen at a constant rate, typically between 0.5% and 2.0% per minute. Slower rates are used for stiffer soils and faster rates for softer soils. The displacement and the applied load are measured as the specimen is sheared. A stress/strain curve is plotted containing these data points. The unconfined compression strength,  $q_u$ , is the peak of the stress/strain curve. The simple relationship derived from the specimen's Mohr circle dictates that the undrained shear strength  $s_u$  is equal to  $q_u/2$ .

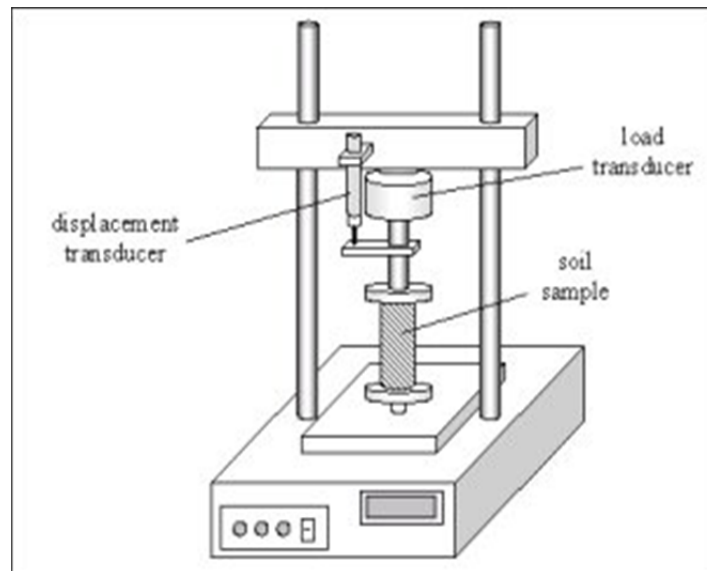
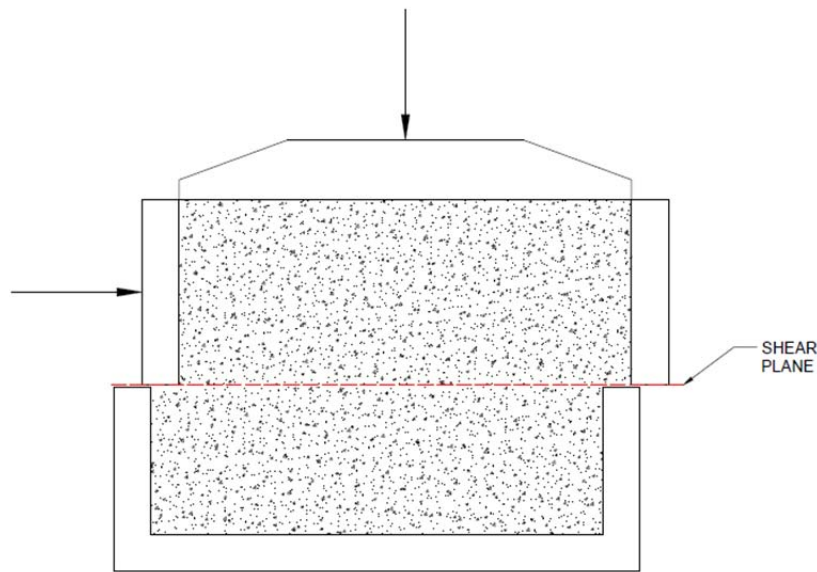

*Figure 3: Unconfined Compression Test (Smith, 2006)*

There is some applicability of the unconfined compression to the type of loadings observed in railroad subgrades. The unconfined compression test and the undrained shear strength are used to determine how a soil will perform in rapid loading situations where pore water does not have time to drain from the soil. Railroad loadings, while cyclic in nature, are still considered relatively fast loading periods. The unconfined compression test is still used today primarily because of its simplicity and repeatability.

### 3.1.2 Direct Shear (ASTM D3080)

Also known as the shear box test, the direct shear test provides shear strength properties for soils with consolidated, drained loading conditions. The test is typically performed on noncohesive soils (i.e. soils for which the unconfined compressive strength cannot be determined). In this test a cylindrical specimen is placed inside a square shear box. The diameter of the specimen must be at least 2 inches or 10 times the minimum particle size, whichever is larger. The box consists of an upper and lower portion with the failure plane occurring between the two portions (see Figure 4). A loading cap applies a normal force to the soil specimen while a load cell applies a shearing force to the specimen. The lower portion of the box remains stationary. The applied normal stress (i.e. overburden stress) and shear stress at failure are recorded. Typically, at least three tests are run varying the applied normal stress. Each test will provide one point along the Mohr-Coulomb failure envelope. The resulting slope of the Mohr-Coulomb failure envelope is known as the friction angle (see Figure 5).



*Figure 4: Direct Shear Test*

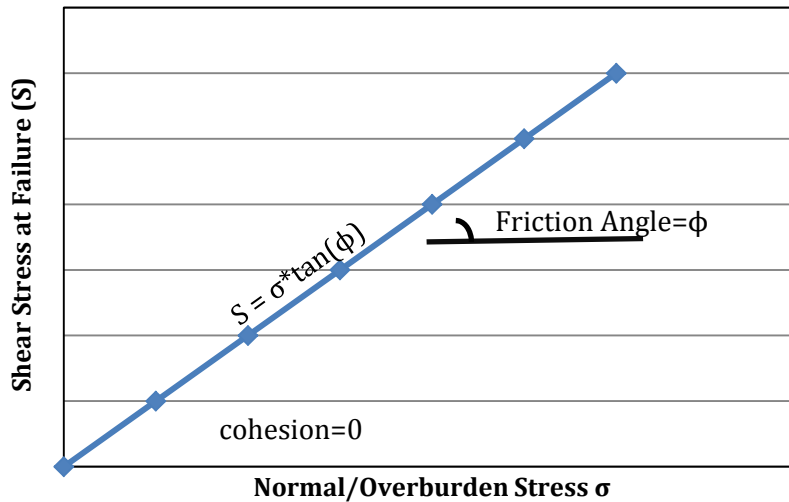

**Figure 5: Stress relationship for a direct shear test on granular soils**

Because an appropriate height cannot be determined to calculate shear strains, a stress-strain relationship and any associated moduli cannot be determined from this test. Advantages to the direct shear test include its relative simplicity and results that can be obtained quickly relative to other consolidated, drained shear strength tests. Failure in the direct shear box is forced to occur on the horizontal plane between the portions of the box and thus may not occur on the weakest plane in the soil.

The direct shear test can also be used to study the interface between two dissimilar materials. The direct shear test could be used to analyze the interface between the dissimilar layers in a trackbed (subgrade and ballast, subgrade and asphalt, subgrade and granular sub-ballast, etc). The study of these interfaces is important for understanding the lateral stability of a trackbed's cross-section. Little research is available on lateral stability of a trackbed. However, frictional interface between trackbed layers may influence track buckling or lateral stability under eccentric loads. While simple in nature, the direct shear may be the most convenient test available to study these interfaces.

### **3.1.3 California Bearing Ratio (ASTM D1883)**

The California Bearing Ratio (CBR) Test has been used for many years for highway and airfield design. The CBR test is a penetration test used to determine the bearing capacity of a soil by comparing it with that of a well-graded crushed stone – namely California limestone. The CBR value reported for a given penetration value is a percentage of the load required to obtain that same penetration value for California limestone. Typical CBR values range from 1.0 to 5.0 for fine-grained soils, 5.0 to 80.0 for coarse-grained soils and 80+ for high-quality rock. To perform the test a 50 mm plunger is penetrated into a standard mold soil sample (see Figure 6) at a constant rate,

typically 0.05 inches per minute. The load required to maintain that rate is recorded at penetrations ranging from 0.025 inch to 0.300 inch. The CBR is calculated by comparing the ratio of the load required for a given soil at 0.10 inch penetration with that for the California Limestone (1000 psi). This relationship is shown in Equation 3.

$$CBR(\%) = 100 * \frac{P_s}{P_c} \quad (3)$$

$P_s$  = Measured load for soil at given penetration

$P_c$  = Measured load for California Limestone at given penetration

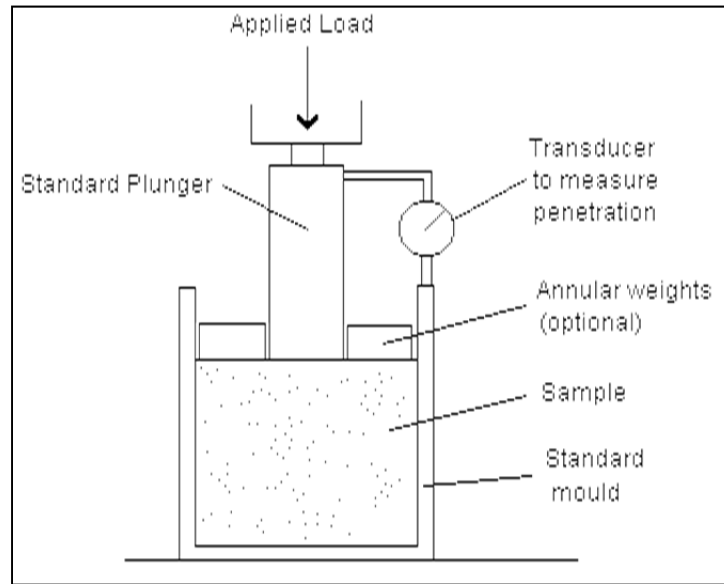

**Figure 6: California Bearing Ratio Test (Wilkinson, 1997)**

CBR tests can be performed at various moisture contents and dry densities as obtained from standard Proctor testing. They can also be run using soaked or unsoaked samples. Typically CBR values are reported using soaked tests for highway applications, assuming the subgrade is at its weakest condition. The unsoaked condition may be more appropriate for railroad applications (Rose & Lees, 2008).

While CBR results are technically an indication of strength, researchers have developed several empirical formulas relating CBR to soil resilient modulus ( $E_R$ ) for roadway subgrade, including:

For fine-grained soils with soaked CBR < 10:

$$E_R (psi) = 1500 * CBR \quad (AASHTO, 1993) \quad (4)$$

For a wide range of soils:

$$E_R \text{ (psi)} = 2555 * CBR^{0.62} \quad (\text{AASHTO MEPDG}) \quad (5)$$

As with most empirical relationships, Equations 4 and 5 have proven inconsistent at times and it is still debatable under which conditions it is suitable to use them (Sukumaran, 2002). The relationships are commonly used as estimates, though, because of the complex testing and equipment necessary to directly calculate a soil's resilient modulus. This is discussed further in the section on cyclic loading of soils.

### 3.1.4 Triaxial Testing (ASTM D2850, D4767)

Triaxial testing uses a well-established device to determine a soil's strength properties. A cylindrical specimen is placed into a pressurized cell containing a fluid. The soil sample is isolated from the fluid using a rubber membrane. Confining stress is placed on the sample and a vertical deviator stress is applied. Figure 7 shows the standard triaxial cell setup. This test is particularly versatile because it can test soils under a number of different conditions. Triaxial tests can be run on consolidated or unconsolidated, as well as drained or undrained specimens. This establishes two stages of loading – a consolidation stage and a shearing stage. Long term, drained triaxial testing can take numerous days to run, while an undrained test condition may only take 30 minutes to test.

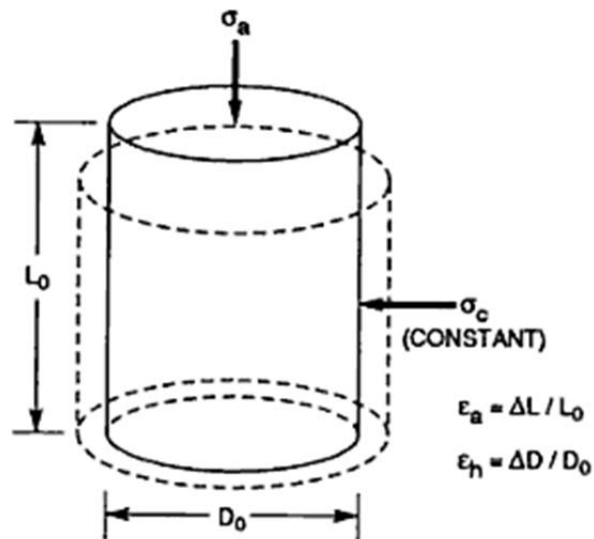
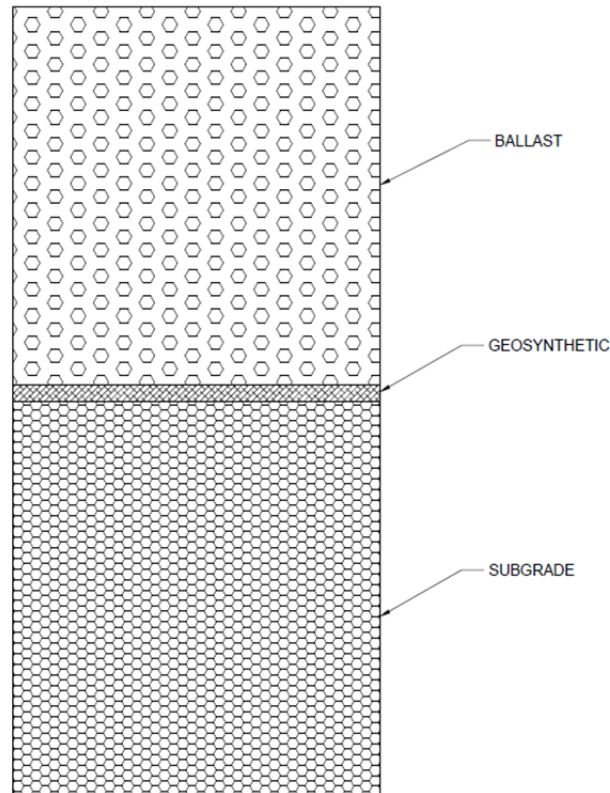

Figure 7: Triaxial Test parameters (Selig and Waters, 1994)

### 3.1.5 Split Cell Triaxial Testing

A form of triaxial testing that may have implications to achieve a better understanding of railroad trackbed behavior is split cell testing. Split triaxial cells are simply cells containing two different materials. Subgrade-ballast split cell testing could be used to analyze the potential for pumping of subgrade fines into ballast, how such a failure would impact the track performance, and how geotextiles perform in influencing such a mechanism. Figure 8 presents a possible setup of a triaxial cell to test this phenomenon.



*Figure 8: Example of what a split cell triaxial sample might look like to test the effectiveness of a geosynthetic in pumping prevention*

### 3.1.6 Cyclic Loading of Soils

While static loading situations are much easier to analyze, the repeated loads observed in railroad trackbeds requires cyclic analysis. As locomotives and train cars pass over a particular area of track, loading is applied and then released. (O'Reilly and Brown, 1991) provide a general overview of the nature of cyclic loading and how it differs from monotonic and static loading conditions. Two phenomena essentially occur in cyclically loaded soils – the accumulation of plastic strain after repeated cycles and the potential buildup of pore pressure when loading occurs sufficiently quick to be considered an “undrained” loading condition (O'Reilly and Brown, 1991). The accumulation of plastic strain in the subgrade may result in track geometry defects. The



buildup of pore pressure could result in shear failure of the subgrade due to reduced effective stress. The obvious concern for pore pressure buildup exists when the subgrade is saturated beyond its optimum moisture content. Historically, far less attention has been given to cyclic loading of soils, and there are only a few tests to understand its nature. Following is a brief overview of such tests.

### 3.1.6.1 Repeated Load Triaxial Test (Cyclic Triaxial) (ASTM D3999)

The cyclic triaxial test is used to measure a soil's resilient modulus ( $M_r$  or  $E_r$ ). The setup for the test is essentially the same as shown in Figure 7. The deviator stress applied monotonically in the standard triaxial, however, it is varied in the repeated load triaxial test to produce a cyclic loading. Typical stress-strain behavior can be seen in Figure 9.

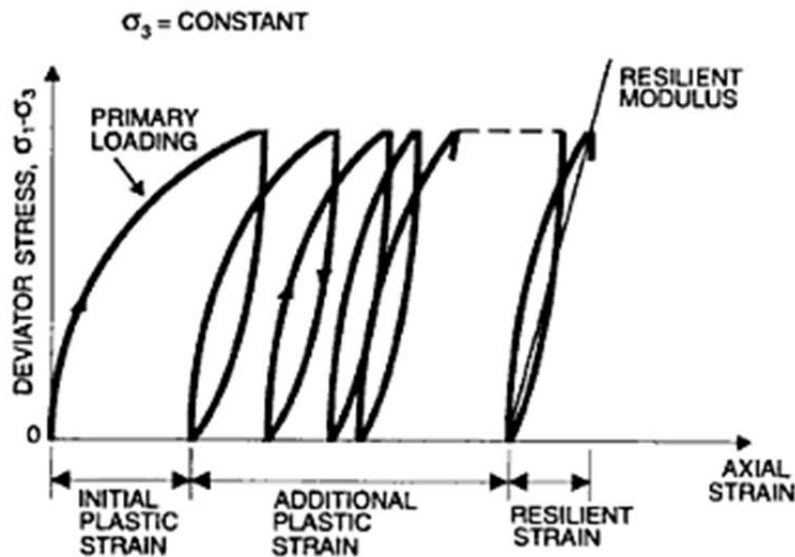

*Figure 9: Typical stress-strain behavior of a cyclically loaded soil showing the accumulated plastic strain and resilient modulus (Selig and Waters, 1994)*

Triaxial devices have been modified to measure small strain stiffness by the application of shear wave loads. This testing obtains a small strain shear modulus ( $G$ ) value for the sample.

### 3.1.6.2 Simple Shear Apparatus (SSA) (ASTM D 6528)

The simple shear apparatus was developed to reduce the non-uniform stress conditions that are developed in the standard split box shear device. The test specimen is simply a circular or rectangular sample that is sheared on its upper and lower surfaces as shown in Figure 10a). This test has been widely used in commercial cyclic load testing (O'Reilly and Brown, 1991).

### 3.1.6.3 Hollow Cylinder Apparatus (HCA)

The hollow cylinder test requires a hollow cylindrical specimen of soil. Up to four independent loads may be placed on the sample – the internal pressure against the interior wall of the sample, the exterior pressure against the exterior wall of the sample, an axial load, and a torque about the axis of the specimen as shown in Figure 10b) (O'Reilly and Brown, 1991). The test has primarily been used in research applications. Its main advantage over triaxial type setups is its allowance of principal stress rotation (due to the application of shear force).

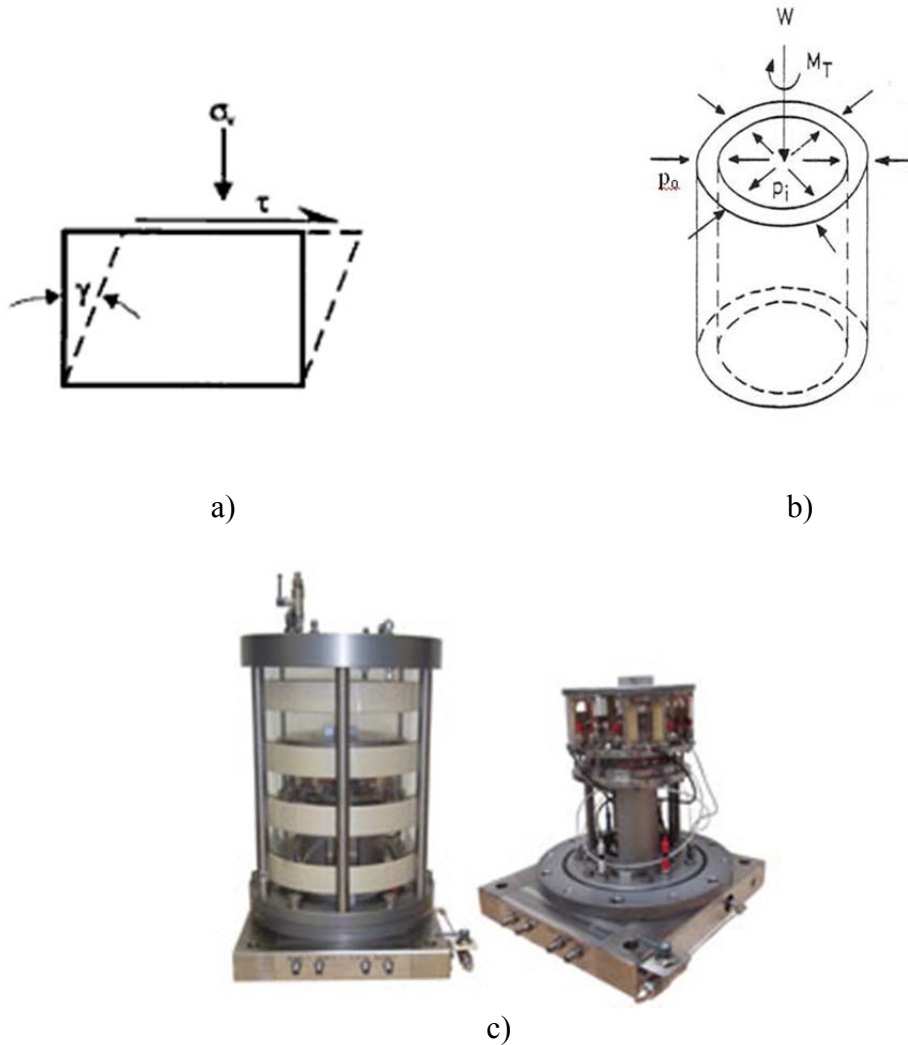

**Figure 10: Cyclic loading tests: a) Simple Shear sample (Selig and Waters, 1994), b) Hollow Cylinder Apparatus sample (Gonzalez, 2005) and c) Resonant Column Apparatus (GDS)**

### 3.1.6.4 Resonant Column Apparatus (RCA) (ASTM D4015)

The Resonant Column Apparatus subjects a hollow cylindrical or cylindrical specimen to cyclic shear loads applied at the cylinder head. The head vibrates in a torsional mode. Measurements of the resonant frequency and amplitude of the load applied are taken. The shear stiffness of the soil can be computed from this data (O'Reilly and Brown, 1991). A standard RCA is shown in Figure 10c).

## 3.2 In-Situ Tests

While some laboratory tests may be appropriate and can be performed on railroad subgrade soils, in-situ testing appears to have greater application to the railroad industry. Roadways and railways present unique geotechnical design concerns in that they cross extremely varied soil conditions from one mile to the next. Contrast this with a building site that may only be one or two acres in area. In a standardized method of trackbed design, in order to account for these variations, numerous samples for laboratory tests would be required at each change of subgrade conditions. These samples would then be taken to the laboratory, tested, and results generated. In-situ testing serves to bypass the cost and inconvenience of laboratory testing by testing and generating results on site. Of particular interest to the transportation field is continuous in-situ testing methods, some of which are discussed below.

### 3.2.1 Field Vane Shear Test (FVT) (ASTM D2573)

The vane shear test uses a simple cylindrical device with attached vanes to induce shear failure in a subgrade soil by applying a measured torque. Torque can either be applied by hand, or mechanically. A vane shear device is shown in Figure 11. For a standard vane shear device, the blade height to diameter ratio is 2 and the undrained shear strength is estimated using equation 6 (Selig and Lutengger, 1991).

$$s_u = \frac{6M}{7\rho D^3} \quad (6)$$

Where:

M = measured torque

D = vane diameter

The FVT cannot be run through the ballast and thus requires a borehole to reach the subgrade layer. Test results vary based on the size of vane, height to diameter ratio, rate of rotation and time to initiate rotation after insertion (Selig, 1991). It should thus be considered as a simplified, rough testing method that generally only has applicability in soft to medium clays (See Table 1).

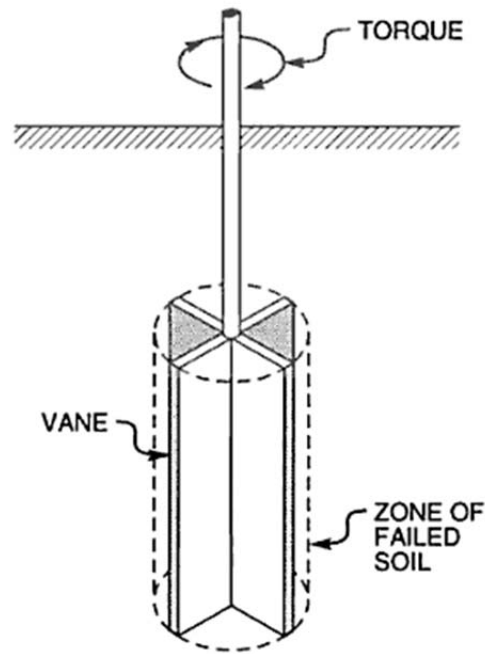
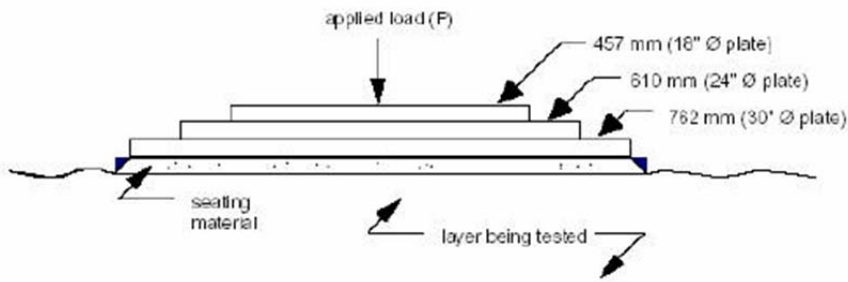

*Figure 11: Field Vane Shear Test (Selig and Waters, 1994)*

### 3.2.2 Plate Load Test (PLT) (ASTM D1196)

Figure 12a) shows the setup of a standard plate load test. A hydraulic jack presses a steel bearing plate into the soil. The jack is applied using a truck (see Figure 12b)), machinery or some other counter weight to fixate the jack in place. The applied pressure and surface deflection are recorded in order to calculate the modulus of subgrade reaction,  $k$ .

The plate load test has been used in European and Japanese track design to determine the subgrade stiffness. The Japanese have incorporated the plate load test results into their Design Standards for Railway Structures and Earth Structures (Design Standards for Railway Structures and Commentary, 2007). Plate load tests are run on the upper embankment of the trackbed. Along with average density of compaction requirements, minimum  $k_{30}$  values are specified for various performance ranks. It does not appear that the  $k$  value is correlated to any other parameter.



a)

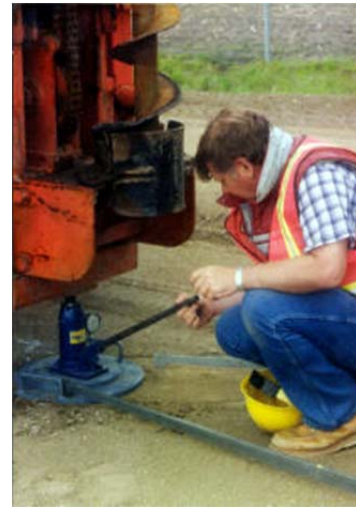

b)

**Figure 12: a) Plate Load Test diagram showing various plate sizes available and b) PLT being performed from below a truck (WSDOT)**

The PLT presents some inherent difficulties, however, for use in railroad applications. In order to have sufficient force applied to the plate, a counter weight is needed. The test is relatively cumbersome and difficult to repeat. It requires an open, compacted area of subgrade, thus it could only be used on new subgrade and not on existing track structures. The application of the PLT on existing American railroads is likely limited due to these restrictions.

Using this test, AASHTO (1993) recommends Equation 7 to estimate the resilient modulus,  $E_r$ .

$$E_r = 19.4 * k \quad (MPa \text{ or } psi) \quad (7)$$

Because the  $k$  value is not a property of the soil and is dependent on the area of the plate that is used, the plate area is usually reported as a subscript. For example,  $k_{30}$  refers to the diameter of the plate being 30 inches.

### 3.2.3 Standard Penetration Test (SPT) (ASTM D1586)

This well established test uses a thick-walled, split-spoon sample tube 2 inches in diameter to recover soil samples as well as measure resistance to penetration throughout a soil stratum. To perform an SPT, a bore hole is drilled at the desired location and depth of testing and the sampler is lowered into the hole. The sampler (either 18 inches or 24 inches in length) is driven in successive intervals of 6 inches using a 140 lb weight

dropped from a 30-inch height (see Figure 13). The N-value, or standard penetration resistance, is the sum of the number of blows required to drive the sampler one foot. This foot is taken as the last 12 inches of the 18-inch sampler or the middle 12 inches of the 24-inch sampler. There are countless empirical formulas equating N-values to bearing capacity, undrained shear strength, friction angles and other soil parameters. However, correlations are often site/soil specific (Selig, 1991).

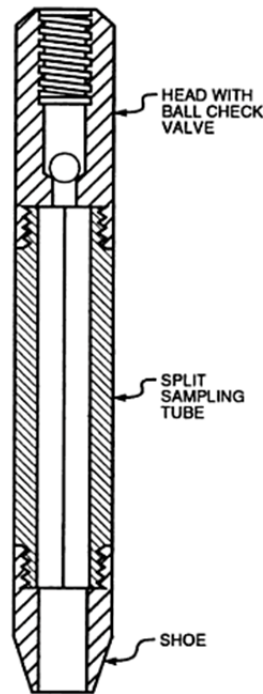

**Figure 13: Standard Penetration Test with split-spoon sampler (Selig and Waters, 1994)**

Advantages to the SPT include its long history and availability among testing contractors. The test could be used qualitatively to locate hard or soft areas and is the only in-situ test able to recover a sample during testing (Selig, 1991). However, the N-values produced from two different apparatuses have been shown to differ by as much as 100% (ASTM D1586). For use on existing trackbeds, ballast would have to be cleared before subgrade soil was reached and bore holes would need to be drilled for each successive 18 inch interval to be tested. This would add considerable cost and time to obtaining a useful subgrade characterization along an existing railroad track.

### **3.2.4 Cone Penetration Test (CPT/CPTU) (ASTM D3441/D5778)**

The CPT, or cone penetration test is an in-situ method of determining a soil's properties. A cone is placed on the end of a rod and is penetrated into the ground at a constant rate, typically 20 mm/sec. As the cone is pushed, measurement of the resistance to penetration is taken. This is calculated simply by measuring the force required to maintain a constant rate of penetration and dividing it by the surface area of the cone.

Sleeve friction, or the friction acting against the penetration, is also measured. In a CPTU or “piezocone test,” pore water pressure in the soil is also measured with the use of a porous filter and pressure transducer (see Figure 14).

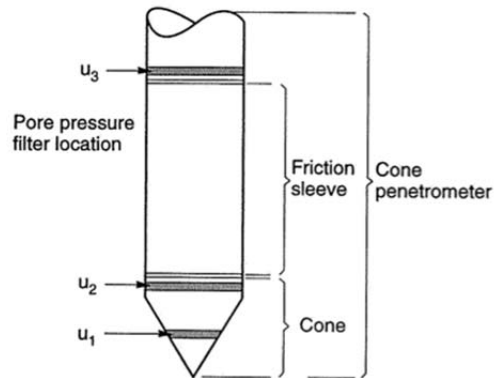

**Figure 14: Typical CPTU cone showing three possible locations for pore pressure measurement (Selig and Waters, 1994)**

Advantages of the CPT over traditional boring and sampling procedures are its cost effective results, ability to provide nearly continuous stratigraphy profiles, and high reliability (Lunne, Robertson, Powell, 1997). The cone penetration test is extremely convenient and might be even more convenient for application in the railroad industry. Because relatively shallow profiles (less than 50 feet) would be needed for trackbed design and analysis, a CPT truck outfitted with High Railers (as shown in Figure 15) would be a very efficient means of determining soil parameters along a long rail corridor in a short amount of time.



**Figure 15: Stratigraphics CPT truck outfitted with High Railers performing penetration testing on an existing trackbed in Wisconsin (Stratigraphics)**

Parameters that can be determined from CPT testing include pore pressure, effective friction angle, undrained shear strength, density index, coefficient of consolidation, and small strain shear modulus (Lunne, Robertson, and Powell, 1997). Small strain shear behavior is more accurately determined when the cone is equipped with a geophone or accelerometer to measure compression and shear waves. Shear or compression waves are induced at the surface and can be measured by the geophone at any depth of penetration. The geophone supplement to the CPT may prove beneficial for railroads in the future. Train loadings are cyclic in nature and produce small strains in the subgrade soil. A small strain modulus would be preferred over a resilient modulus for railroad loading conditions.

A Dynamic Cone Penetration Test (DCT) uses the same driving device as the SPT and blow counts per 6 inches of penetration are measured. A hand operated DCT was described by Ayres and Thompson (1989). A falling weight is used to drive the 60 degree cone tip into the ground. This test may be useful in determining approximate depths to ballast and subballast layers (Selig and Lutenecker, 1991).

### 3.2.5 PANDA Penetrometer 3

A recently developed, hand-held version of a dynamic cone penetration test called the PANDA Penetrometer has seen increased use in railroad trackbed assessment. The PANDA is a lightweight dynamic penetrometer developed in France. The penetrometer consists of a rod with a 2, 4, or 10 cm<sup>2</sup> cone on its end. The rod is driven into the ground using variable, manual energy supplied from a hammer. Each time the rod is struck, the blow energy and the depth of penetration are measured using a small central acquisition unit. Figure 16 shows a standard PANDA Penetrometer setup. The dynamic cone resistance,  $q_d$ , is calculated using Equation 7 (LCPC and CETE, 2007(2)).

$$q_d = \frac{1}{2} mV^2 \frac{1}{Ae} * \frac{m}{m+m'} \quad (7)$$

Where:

$m$  = mass of the PANDA head

$m'$  = mass of the tube + cone

$e$  = depth of penetration

$A$  = section of the cone

$V$  = velocity of the hammer at impact



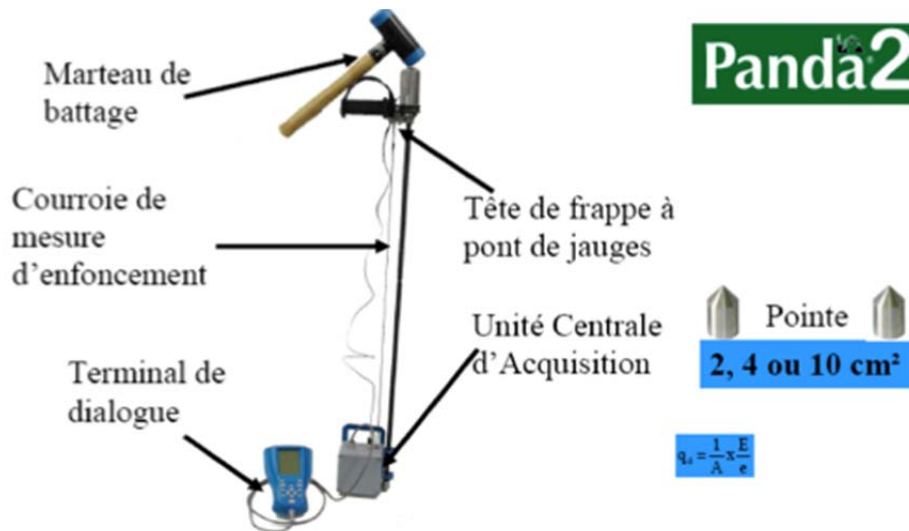
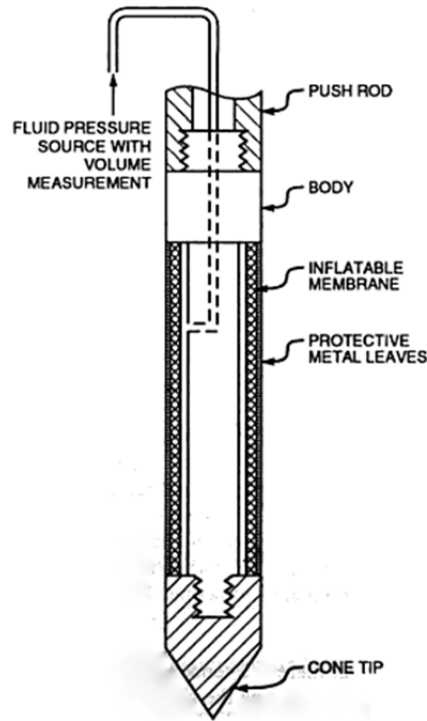

**Figure 16: PANDA Penetrometer (LCPC and CETE, 2007)**

After penetration, an endoscope is used to classify the soil type and stratification. LCPC and CETE (2007) affirm that the test has been reliable and has compared favorably with other standard in-situ tests in obtaining design parameters. The results have also been used to estimate an elastic modulus for various layers of the trackbed (LCPC and CETE, 2007 (2)). The PANDA can penetrate through the ballast eliminating unnecessary track disturbances and allowing more data collection. The French SNCF has increased their use of this test because of its economy, speed, and reduced level of disturbance.

### 3.2.6 Full Displacement Pressuremeter Test (FDPMT) (ASTM D4719)

The FDPMT requires the penetration of a cylindrical probe into the soil and a subsequent induced volume increase of the probe. As the probe's membrane is expanded, the pressure acting on the cylindrical cavity in the soil is measured along with radial displacement. A cavity strain of roughly 30% is produced (Selig and Lutenegeger, 1991). The FDPMT typically does not require a bore hole and can be run from the ground surface. It cannot, however, be penetrated through the ballast (Selig and Lutenegeger, 1991). Figure 17 shows a close-up view of the cone.



*Figure 17: Full-displacement Pressuremeter (Selig and Waters, 1994)*

### 3.2.7 Flat Dilatometer (ASTM D6635)

The flat dilatometer is a steel blade shaped device with a steel membrane on one side (see Figure 18). The device is driven into the ground using a penetration rig or truck. At 20 cm intervals, the membrane is inflated using pressurized gas. The pressure required to begin movement of the membrane as well as the pressure required to move its center a distance of 1 mm from the paddle are recorded. A 30 m profile can be obtained in 2 hours (Marchetti, 1980). Results from the dilatometer test have been correlated to various geotechnical parameters including small strain shear modulus, and overconsolidation ratio (OCR). The Material Index,  $I_D$ , obtained from the test has also been shown to correlate well with grain size distribution. For correlations and further discussion, refer to (Marchetti, 1980 and Sully and Campanella, 1989)

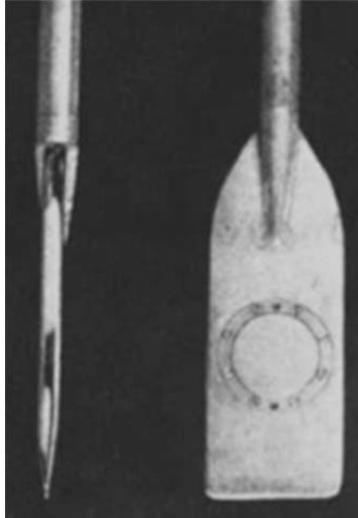

*Figure 18: The Flat Dilatometer (Marchetti, 1980)*

The use of the Dilatometer on railroad subgrade soils has not been observed. Due to the sensitivity of the blade's membrane, it cannot be pushed through ballast layers. The 30 m depth referenced in Marchetti, 1980 would likely not be necessary for railroad applications. Advantages to the DMT include considerable data from closely spaced intervals as well as minimal moving components. The test may be relevant in obtaining geotechnical performance data for high railroad embankments or deeper subgrade conditions.

### **3.2.8 Falling Weight Deflectometer (FWD) and Light Falling Weight Deflectometer (LFWD) (ASTM D4694)**

The FWD and LFWD are two devices used to measure the stiffness of an engineered surface. The testing procedure involves dropping a known weight from a known height onto the surface and measuring deflections at various radial distances from the point of loading (see Figure 19). The LFWD is based on the same concept only is confined in a more portable device with a lighter weight. It is typically used only on subgrade soils and subbase materials in highways.

Historically, the FWD has been used in state highway departments to estimate pavement quality and life cycle. The FWD and other impulse devices are believed to simulate quite effectively the loadings placed on pavements from traffic wheel loads (Nazzal and Mohammad, 2010). A modulus is backcalculated from the loading and deflection data by assuming a modulus for each layer and iterating until the solutions converge (AASHTO, 1993). The AASHTO Mechanistic-Empirical Pavement Design Guide recommends Equation 8 to compute the backcalculated modulus. This process has been made much simpler with the use of FWD computer software. Some research has been conducted in attempt to correlate the backcalculated modulus with the widely used resilient modulus (Nazzal and Mohammad, 2010).

$$E_{FWD} = \frac{0.24P}{d_r r} \quad (8)$$

Where:

P = applied load (lb.)

$d_r$  = surface deflection at radial distance, r (both in in.)

Recently, the LFWD has seen usage in passenger and high-speed passenger rail construction in Europe and Asia. (Lee and Choi, 2011) concluded that the LFWD may have a broader application in railroad engineering after correlating  $E_{LFWD}$  moduli with stiffness parameters determined from plate load and cyclic plate load testing ( $k_{30}$  and  $E_{v2}$  respectively). The LFWD has the flexibility to be used quickly and effectively on the subgrade and subballast as a trackbed is being rehabilitated with a track laying machine. Figure 20 shows a typical LFWD.



***Figure 19: Typical FWD mounted on a trailer for use on highway pavement surfaces. (Dynatest)***



**Figure 20: A LFW being used on an asphalt trackbed layer in Austria. (ÖBB – Austrian Federal Railway)**

### 3.2.9 Portancemètre

The Portancemètre is a recently developed continuous means of testing a subgrade soil's modulus. As seen in Figure 21, the vibrating wheel of the Portancemètre is pulled behind a vehicle during testing. Known forces and measured deflections (to obtain  $k$  values) are used as data points to determine the subgrade's stiffness. Results from the Portancemètre have been calibrated to the static plate load test. The EV2 modulus is determined from the  $k$  value using Equation 9 (LCPC and CETE, 2007(2)).

$$EV2 = 5.26 * k \quad (9)$$

Where:

$k$  = Modulus of subgrade reaction in kN/mm

EV2 = Modulus in MPa

The device is capable of measuring subgrade modulus in the range of 30 – 300 MPa continuously (measurements taken each meter). The Portancemètre can take 15 km of measurements each day at a speed of 3.6 km/h. A recent study by LCPC, a French public research and consulting institution, has researched the possibility of such a system running on railroad track to measure trackbed vertical stiffness (Berggren, 2009).



*Figure 21: The Portancemètre (LCPC)*

### **3.2.10 DyStaFiT (Dynamic Stability Field Test)**

The DyStaFiT device was developed by ARCADIS in The Netherlands. It is composed of a hydraulic base carrier with a mast, a vibrator, and a load plate 2500 mm in diameter seen in Figure 22 (Neidhart and Shultz, 2011). DyStaFiT is capable of generating the static and cyclic-dynamic loading of a train directly to the compacted subgrade. The in-situ, 1:1 scale provides a more representative measure of subgrade performance than a scaled down laboratory test (Neidhart and Shultz, 2011). The testing device can simulate the total number of load cycles expected in the life of a trackbed in just one to two days. DyStaFiT is explicitly mentioned in the German Railways guideline on earth construction as a suitable verification procedure (Neidhart and Shultz, 2011).



*Figure 22: DyStaFiT testing device (Shultz, Dürrwang, and Neidhart, 1999)*



**Table 1: Applicability of Standard In-situ Testing for Various Parameters and conditions (Lunne et. al (1997) and Selig and Lutengger (1991))**

In-Situ Test	Site Characterization		Soil Parameters						Soil Type				
	Determining Soil type	Determining Profile	Pore Pressure (u)	Effective Internal Friction	Undrained Shear Strength	Small Strain Shear Modulus	Elastic Modulus	Overconsolidation Ratio (OCR)	Gravel	sand	silt	soft to medium clay	medium to Stiff clay
Standard Penetration Test (STP)	**	*						*	**	**	**	**	**
Full Displacement Pressuremeter (FDP)	*	*				**			*		**	**	**
Plate Load Test (PLT)					*	**		*	*	**	**	**	**
Field Vane Shear (FVS)	*				**						**	**	*
Flat Dialometer (DMT)	*	**		*	*	*			**	**	**	**	**
Cone Penetration Test (CPT) additionally if CPTU			**	*		*			**	**	**	**	**

\* Applicable  
 \*\* Very Applicable



#### 4.0 Other In-Situ Tests For Railroad Trackbeds

Considering the difficulty and effort required in testing in-situ railroad subgrades, additional tests have been developed to assess performance of the overall trackbed structure. Both the Portancemètre and the DyStaFiT systems have been developed for direct use on the track (LCPC and CETE, 2007(2) and Neidhart and Shultz, 2011). Rolling Stiffness Measurement Vehicles (RSMV) and Track Loading Vehicles (TLV) have been developed and used in Europe as well as the U.S. LCPC and CETE were complicit in the recent development of a modified Portancemètre for track stiffness measurements as seen in Figure 23. The Chinese Academy of Railway Sciences (CARS) was one of the first to develop a rolling stiffness measurement. It uses two cars, one that applies a lighter load and one that applies a heavier load. The difference in track deflections between these two loadings is used to calculate track stiffness (LCPC and CETE, 2007). The TLV at the TTCI test track in Pueblo, Colorado uses a similar setup as the CARS system (see Figure 24). The University of Nebraska at Lincoln has also developed a continuous track stiffness measurement device using a laser to measure track deflection ahead of the rolling wheel (Norman et al., 2004) While these tests are not run directly on the subgrade soil, their results are likely indicative of the subgrade quality and performance. Their main advantage is obviously that they are rail-bound.



*Figure 23: A version of the adapted Portancemètre during its development (LCPC and CETE, 2007)*



*Figure 24: Track Loading Vehicle (TLV) at TTCI test track in Pueblo, Colorado (AAR)*

## 5.0 Discussion and Conclusions

Defects in geometry are normally the primary indicator that maintenance and track adjustments are needed on U.S. trackbeds. Much attention has been spent on measuring and recording geometry in great detail. The root cause of many subsequent geometry issues, however, lies in the subgrade. Understanding how well a subgrade is performing should be the first step in optimizing maintenance scheduling and spending.

With increased car weights, longer trains, and an overall increased demand for railroad transportation in the U.S. comes the need for higher quality track. Recognizing the significant role the subgrade plays in trackbed performance, it is clear that testing procedures and performance indicators must be further refined for this critical layer. The tests described herein have proven useful in modern day geotechnical engineering. They may, however, need modification to meet the needs of the American railroad industry (i.e. faster testing times between trains or placing testing equipment on rail-bound vehicles for better accessibility). In-situ testing often times provides quicker and more relevant results due to less intermediate steps and the absence of any scaling effects. Laboratory testing, especially in the area of cyclic loading, is still relevant for railroad subgrade engineering. Split cell triaxial testing is an option to further understand of subgrade-ballast interaction and the geotechnical properties of fouled ballast. Direct shear testing between trackbed materials also may have implications in lateral track behavior.

Construction of enhanced rail corridors in the U.S. will require upgrading existing track and trackbeds to accommodate higher speeds and heavier loads. As such, an in-situ test that can be transported by and run directly on the rail would be preferable. A continuous test that is run while traveling on the rails would be ideal. While localized testing allows detailed soil data to be obtained from a particular location, continuous testing provides limited knowledge, but on a much broader, more useful scale. It appears as though the European and Asian railroad industries are moving towards testing devices that are track bound. Devices such as the Rolling Stiffness Measurement Vehicle and modified Portancmètre represent the state of the art. They allow continuous, rolling track stiffness measurements. While these tests are not run directly on the subgrade, their results are indicative of the subgrade stiffness and overall effect on trackbed performance. Future versions of these testing procedures will likely better predict subgrade performance without ever having to remove ballast or penetrate into the trackbed.

## References

- American Association of State Highway and Transportation Officials. 1993. AASHTO Guide for Design of Pavement Structures.
- American Association of State Highway and Transportation Officials. 2004. Standard Specifications for Transportation Materials and Methods of Sampling and Testing. 24<sup>th</sup> Edition, 2004.
- American Association of State Highway and Transportation Officials. 2008. AASHTO Mechanistic-Empirical Pavement Design Guide (MEPDG).
- American Association of Railroads (AAR). 2011. TTCI Facilities webpage.
- AREMA. 2010. "Manual for Railway Engineering." Publication of the American Railway Engineering and Maintenance-of-Way Association.
- ASTM Annual Book of Standards. Section 4, Construction. Vol 04.08, Soil and Rock Including:
- ASTM D2487. Standard Test Method for Classification of Soils for Engineering Purposes.
- ASTM D423. Standard Test Method for Liquid Limit of Soils.
- ASTM D424. Standard Test Method for Plastic Limit and Plasticity Index of Soils.
- ASTM D2573. Standard Test Method for Field Vane Shear Test in Cohesive Soil.
- ASTM D3441. Standard Test Method for Deep Quasi-static, Cone, and Friction-cone Penetration Tests of Soil.
- ASTM D1586. Standard Test Method for Penetration Test and Split-Barrel Sampling of Soils.
- ASTM D2216. Standard Test Methods for Laboratory Determination of Water (Moisture) Content of Soil and Rock by Mass.
- ASTM D698. Standard Test Methods for Laboratory Compaction Characteristics of Soil Using Standard Effort (12 400 ft-lbf/ft<sup>3</sup> (600 kN-m/m<sup>3</sup>)).
- ASTM D2166. Standard Test Method for Unconfined Compressive Strength of Cohesive Soil.
- ASTM D1196. Standard Test Method for Nonrepetitive Static Plate Load Tests of Soils and Flexible Pavement Components, for Use in Evaluation and Design of Airport and Highway Pavements.
- ASTM D3080. Standard Test Method for Direct Shear Test of Soils Under Consolidated Drained Conditions.
- ASTM D1883. Standard Test Method for CBR (California Bearing Ratio) of Laboratory-Compacted Soils.
- ASTM D4015. Standard Test Methods for Modulus and Damping of Soils by Resonant-Column Method.
- ASTM D6528. Standard Test Method for Consolidated Undrained Direct Simple Shear Testing of Cohesive Soils.
- ASTM D6635. Standard Test Method for Performing the Flat Plate Dilatometer.
- ASTM D3441. Standard Test Method for Mechanical Cone Penetration Tests of Soil
- ASTM D5778. Standard Test Method for Electronic Friction Cone and Piezocone Penetration Testing of Soils

- ASTM D4719. Standard Test Method for Prebored Pressuremeter Testing in Soils
- ASTM D4694. Standard Test Method for Deflections with a Falling-Weight-Type Impulse Load Device
- ASTM D3999. Standard Test Methods for the Determination of the Modulus and Damping Properties of Soils Using the Cyclic Triaxial Apparatus.
- ASTM D4767. Standard Test Method for Consolidated Undrained Triaxial Compression Test for Cohesive Soils
- ASTM D2850. Standard Test Method for Unconsolidated-Undrained Triaxial Compression Test on Cohesive Soils.
- Ayers, M.E. and Thompson, M.R. 1989. Evaluation Techniques for Determining the Strength Characteristics of Ballast and Subgrade Materials. Department of Civil Engineering, University of Illinois at Urbana-Champaign for Association of American Railroads Affiliated Laboratory Program, July.
- Berggren, E. 2009. Railway Track Stiffness – Dynamic Measurements and Evaluation for Efficient Maintenance. PhD Thesis, Royal Institute of Technology (KTH).
- Design Standards for Railway Structures and Commentary (Earth Structures). 2007. Railway Technical Research Institute. Japan.
- Dynatest. Dynatest FWD/HWD Test Systems. FWD figure obtained from <http://www.dynatest.com/structural-hwd-fwd.php>
- Gallego, I., Muñoz, J., Rivas, A. and Sánchez-Cambronero. 2011. Vertical Stiffness as a Design Parameter of a Transverse Section in High Speed Lines. Proceedings from Railway Engineering. London, 2011.
- GDS Instruments. Resonant Column Apparatus. RCA figure obtained from [http://www.gdsinstruments.com/resonant\\_column.htm](http://www.gdsinstruments.com/resonant_column.htm).
- Gonzalez, Daniel Barreto. 2005-2008. Dem simulations of hollow cylinder tests on cohesionless soils. HCA Figure obtained from <http://www3.imperial.ac.uk/geotechnics/people/researchers/danielbarreto>.
- Illinois Center for Transportation (ICT). Project Spotlight Archives. FWD Figure obtained from [http://ict.illinois.edu/Spotlights/project\\_spotlights\\_archive.aspx](http://ict.illinois.edu/Spotlights/project_spotlights_archive.aspx).
- Hay, William Walter. 1982. Railroad Engineering. Wiley, second edition.
- Lee, Seong-Hyeok and Choi, Chan-Yong. 2011. Correlation Between Bearing Capacity (K30) and Elastic Modulus (ES) Using the LFW Test. Proceedings from Railway Engineering. London, 2011.
- LCPC. 2011. The Portancemètre. Article obtained from <http://www.lcpc.fr/english/products/catalogue-of-mlpc-r-equipment/fiche-268/article/portancemetre-1092>
- LCPC and CETE. 2007. Adapted “Portancemetre” for Track Structure Stiffness Measurement on Existing Tracks. Deliverable D2.1.2 prepared on Project No. TIP5-CT-2006-031415 – Innotrack.
- LCPC and CETE. 2007. (2) Methods of Track Stiffness Measurement. Deliverable D2.1.11 prepared on Project No. TIP5-CT-2006-031415 – Innotrack.
- Lunne, T., Robertson, P.K., and Powell, J.J.M. 1997 Cone Penetration Testing in Geotechnical Practice. Blackie Academic and Professional, an imprint of Chapman & Hall. London. 1997

- Marchetti, S. 1980. In Situ Tests by Flat Dilatometer. *Journal of Geotechnical Engineering Division, ASCE*, Vol. 106, pp. 299-321.
- Nazzal, Munir D. and Mohammad, Louay N. 2010. Estimation of Resilient Modulus of Subgrade Soils Using Falling Weight Deflectometer. *Transportation Research Record: Journal of the Transportation Research Board*, No. 2186, pp. 1-10.
- Neidhart, Thomas, and Shultz, Gerhard. 2011. Dynamic Stability of Railway Tracks – DyStaFiT, and Innovation in Testing. *Proceedings from Georail*. 2011.
- O’Reilly, M.P. and Brown, Stephen F. 1991. *Cyclic Loading of Soils*. Blackie.
- Norman, C., Farritor, S., Arnold, R., Elias, S.E.G., Fateh, M., and Sibaie, M.E. 2004. Design of a System to Measure Track Modulus from a Moving Railcar. *Proceedings from Railway Engineering*. London. 2004
- Rose, Jerry G. and Konduri, Karthik Charan. 2006. KENTRACK — A Railway Trackbed Structural Design Program. *Proceedings of the American Railway Engineering and Maintenance of Way Annual Conference*. Louisville, Kentucky. September 2008
- Rose, Jerry G. and Lees, Henry M. 2008. Long-Term Assessment of Asphalt Trackbed Component Materials’ Properties and Performance. *Proceedings of the American Railway Engineering and Maintenance of Way Annual Conference*. Salt Lake City, Utah. September 2008
- Rose, Jerry G., Teixeira, Paulo F. and Ridgeway, Nathan E. 2010. Utilization of Asphalt/Bituminous Layers and Coatings in Railway Trackbeds – A Compendium of International Applications. *Proceedings from the Joint Rail Conference*. Urbana, Illinois, 2010.
- Selig, Ernest T. and Lutenecker, A.J. 1991. Assessing Railroad Track Subgrade Performance Using In-situ Tests. *Geotechnical Report No. AAR91-369F*. University of Massachusetts. Amherst, Massachusetts.
- Selig, Ernest T. and Waters, John. (1994). “Track Geotechnology and Substructure Management.” Thomas Telford Publications.
- Shultz, G., Dürrwang, R. and Neidhart, T. 1999. *Earth Structures for High-Performance Railways – New Concept*. ARCADIS Special Issue.
- Smith, Ian. 2006. *Elements of Soil Mechanics*. Blackwell Publishing. 8<sup>th</sup> Edition.
- Stratigraphics. CPT Geotechnical and Geo-Environmental Exploration. High Speed Rail Projects. CPT truck figure obtained from <http://stratigraphics.com/projects/p2.html>.
- Sukumaran, Beena. (2002). “Suitability of Using California Bearing Ratio Test to Predict Resilient Modulus.” *Proceedings of the Federal Aviation Administration Airport Technology Transfer Conference*.
- Sully, J.P. & Campanella, R.G. 1989. Correlation of Maximum Shear Modulus with DMT Test Results in Sand. *Proc. XII International Conference on Soil Mechanics and Foundation Engineering*, Vol. 1, pp. 339-343.
- Washington State Department of Transportation. WSDOT Pavement Guide. Design Parameters. Plate Load Figure obtained from Section 2 – Subgrade.
- Wilkinson, David. 1997. *Pavement Design – Foundation Design*. Duram University. CBR Figure obtained from <http://www.dur.ac.uk/~des0www4/cal/roads/pavdes/pavedes.html>

*For more information or a complete publication list, contact us at:*

**KENTUCKY TRANSPORTATION CENTER**

176 Raymond Building  
University of Kentucky  
Lexington, Kentucky 40506-0281

(859) 257-4513  
(859) 257-1815 (FAX)  
1-800-432-0719  
[www.ktc.uky.edu](http://www.ktc.uky.edu)  
[ktc@engr.uky.edu](mailto:ktc@engr.uky.edu)

*The University of Kentucky is an Equal Opportunity Organization*